

2015 Conference on Canadian Stewardship and Recycling Council of Alberta Conference

We are delighted to have you exhibiting, and to announce that GES CANADA has been selected as your Official Service Contractor for the Conference on Canadian Stewardship and Recycling Council of Alberta. We trust you'll find the exhibit opportunity to be an effective market place for your products and services.

Listed below is some general information to help with your preparations for this event.

Following is the exhibitor service manual.

Venue: Fairmont Banff Springs Conference Centre

Each **8'x10'** draped display booth includes

8' high backwall drape

3' high sidewall drape

1 - 6' skirted table (**4' option, see Page 6**)

2 - chairs

Shipping: Please note the Fairmont Banff Springs does not handle exhibitor goods. Boxes and displays are to be shipped to GES, not the hotel. If you are shipping items under 200lbs and unskidded we can hold in our office, please contact our office for the small shipment materials handling service form and address BEFORE Shipping. Do not ship small items to the warehouse.

Shipping: GES is offering Transportation as well as materials handling services and a 10% discount will apply to warehouse materials handling if it and round trip logistics are ordered. To hire GES as your shipper as well as materials handler, please see pages 3 and 11. For shipments not requiring GES logistics, please refer to the materials handling form, page 3, address labels are on page 5. Pre show storage is in Calgary, but the pick up will be from show site in Banff - goods are not returned to Calgary for pick up. Tear out is Friday 2 pm, if hiring GES logistics, goods will be picked up that day. If using another carrier, pick up at the Fairmont Banff Springs would need to be arranged by your company by 5pm. Small shipments held for courier pick up Monday will be charged storage. Please refer to the materials handling order form for details, and if you have other questions, please contact our office.

Carpet: The Van Horne C Ballroom and Foyers are carpeted. If you would like additional carpeting for your booth, please contact our office.

Power: GES Canada is proud to be the exclusive supplier of temporary power and lighting for exhibits at the Fairmont Banff Springs Conference Centre. If you require any electricity at your booth, please see page 8.

Exhibit Hours:

Move In / Installation - Wednesday September 30th, 2015 10am - 12pm

Exhibits Open - Wednesday September 30th, 1pm - 5pm

Thursday October 1st, 8am -5pm

Friday October 2nd, 8am - 2pm

Move out / Dismantle - Friday October 2nd, 2pm - 5pm

Following is the exhibitor service manual with information and order forms for a variety of services. Please note there is a discount offered on items ordered 2 weeks in advance. Please review each of the forms, complete the forms for services you require and return them to our office promptly. The payment and credit card charge authorization form is provided to summarize and pay for your total order.

We realize that exhibiting in a tradeshow can be complicated. If you need assistance with your orders or additional information, please call our team at **(403) 762-2828**, or you can reach us by email at **BANFF@GES.COM**.

We are looking forward to a successful meeting and appreciate your support.
Thank you for your participation and please let us know if we can assist you in any way.



Display #

Canadian Stewardship / RCA Conference
September 30th - October 2nd, 2015
Fairmont Banff Springs

Payment & Credit Card Charge Authorization

DISCOUNT DATE:

PO Box 960 Banff Alberta T1L 1J4 Phone: 403 762-2828 Fax: 403 762-2777 Email: banff@ges.com

September 16th, 2015

COMPANY NAME, EMAIL ADDRESS, STREET, CITY, PROVINCE, POSTAL CODE, PHONE, EXT, FAX, CONTACT NAME, DIRECT PHONE OR EXTENSION

I agree in placing this order that I have accepted GES CANADA payment policy and GES CANADA Terms & Conditions of Contract

Credit Card Charge Authorization

(All Information Must Be Provided)

PLEASE SIGN, AUTHORIZED SIGNATURE, AUTHORIZED NAME - PLEASE PRINT, DATE

PROVIDE EXPIRATION DATE, EXPIRATION DATE, Account #, MasterCard, VISA, American Express

Payment Policy

Payment for Services - GES CANADA requires payment in full at the time services are ordered. Further, GES CANADA requires that you provide a credit card authorization with your initial order.

CARDHOLDER'S NAME PLEASE PRINT, PLEASE SIGN, CARDHOLDER'S SIGNATURE, DATE

Discount Pricing - To qualify for discount pricing, orders must be received with payment on or before the discount price deadline.

Method of Payment - GES CANADA accepts American Express, Mastercard, Visa, cheque and wire transfers.

Third Party Billing - Each exhibiting firm is ultimately responsible for all charges incurred on its behalf.

Tax Exempt - If you are tax exempt in Canada you must provide a GST Exemption Certificate.

Adjustments & Cancellations - No adjustments will be made to invoices after the close of the show.

If you have any questions regarding our payment policy please call GES CANADA at 403.762.2828 or visit the GES CANADA Servicentre at the show.

Please complete the information and return payment in full with this form and your orders. You may choose to pay by credit card, or cheque, however, we require your credit card charge authorization to be on file with GES CANADA.

For your convenience, we will use this authorization to charge your credit card for any additional amounts ordered by your representative or services rendered to your company for this event.

To simplify payment, send a cheque payable to GES CANADA for your entire order or note the amount to be charged to your credit card.

Calculation of Orders

Table with 2 columns: Item Description and Amount. Includes rows for Material Handling, Furniture & Accessories, Specialty Items, Electrical & Lighting, Installation & Dismantle, GEM Counters & Showcases, Transportation, Subtotal, 5% GST, and FULL PAYMENT DUE.

Charge my credit card in the amount above [], Enclosed is a cheque in the amount above [], GST #R104060264

Material Handling Order Form

PO Box 960 Banff Alberta T1L 1J4 Phone: 403 762-2828 Fax: 403 762-2777 Email: banff@ges.com

MATERIALS HANDLING SERVICE

The Fairmont Banff Springs does not handle exhibitor goods

Ship Prepaid Only — Collect shipments will be refused.
 All charges are based on in-bound weights (min. charge applies), or outbound if larger, and are per shipment received.
 Call our office if you have more than one shipment

Rates Include:

- **Storage** at the Calgary Warehouse for up to 30 days
- Unloading materials and delivery to your booth
- Removing empty shipping containers from your booth, storing empties, and returning at close of show.
- Reloading materials onto outbound transportation
- If more than one shipment, call our office .•

Exhibitors should label and consign shipments as follows:

TO: Your Company Name
 75 Dufferin Place SE
 Calgary, Alberta T2C 4M3
 Attn: GES Banff
 Show Name: Canadian Stewardship/RCA Conference
 Booth # _____

\$360.00 MINIMUM CHARGE (UP TO 400LBS)

Late shipments, call our office with details/instructions, do not ship to the hotel

Small shipment materials handling is available. If you have unskidded items under 200lbs (courier) please contact our office BEFORE shipping, for the small item form and ADDRESS. Do not ship small items to the warehouse.

ALL WAREHOUSE SHIPMENTS RECEIVED AFTER SEPTEMBER 25TH ARE SUBJECT TO A LATE HANDLING CHARGE. Van lines, loose, uncrated or improperly packaged materials may be assessed a special handling fee. GES CANADA is not responsible for concealed damage or damage due to improper packaging. A surcharge is assessed for special trips, handling of shipments arriving late at the warehouse and for shipments arriving at Show-Site after scheduled set-up times, or arriving without service being ordered. If your designated carriers do not pick up or make destination delivery of your shipment on time, neither show management nor contractor will be liable for any resulting delays. Please see the following page for full details of terms and conditions of this service. Shipments over 400lbs will be charged \$85 per 100lbs or part of above 400lbs. Pieces that will not fit on a semi, cannot be moved with a pallet jack, would incur additional attention and charges. Please contact our office if extra services are required for a quote.

Return: Post show pick up will be from showsite. Freight is not returned to Calgary for pick up, and must be picked up by 5 pm Friday, (trucks checked in by 4pm) or will be sent forced. If hiring the GES Transportation service this will be scheduled for you by GES. Your company rep on site will need to prepare shipment for return, including filling out a waybill with account number, packaging and securing each piece, removing old labels and labeling each piece for return. Not doing so will incur extra charges. If shipping via courier (under 200 lbs & unskidded only) outgoing storage fees will apply (\$80.00/100lbs ordered in advance, \$120.00/100 lbs arranged on site), and will be charged daily if not picked up by the following business day.

If shipping internationally:

- I understand my company must provide a Commercial Invoice (and any other required forms) with all shipments into and out of Canada, and that I must check that my courier is clearing my goods free domicile and the shipper is responsible for all customs duty and shipping charges for shipments into Canada. Hiring a customs broker is recommended.
- Your company must be the importer on record for your shipment.
- GES CANADA can not be on ANY customs paperwork, your company is the shipper AND the consignee.

SHIPMENT DETAILS AND MATERIAL HANDLING CHARGES

| | | | | |
|-----------|----------|-------|-------------------|------------------|
| Carrier : | Waybill# | # pcs | estimated weight: | estimated price: |
|-----------|----------|-------|-------------------|------------------|

We understand that your calculation is only an estimate. Invoicing will be done from the actual weight. Adjustments will be made accordingly.

I AGREE IN PLACING THIS ORDER THAT I HAVE READ AND ACCEPTED GES PAYMENT POLICY AND GES CANADA TERMS & CONDITIONS OF CONTRACT. SEE NEXT PAGE FOR FULL DETAILS

Outgoing Storage if required \$

TOTAL ESTIMATED CHARGES: \$

Carry this total to the payment and credit card authorization form

Material Handling Information

PO Box 960 Banff Alberta T1L 1J4 Phone: 403 762-2828 Fax: 403 762-2777 Email: banff@ges.com

Material Handling is the unloading of your exhibit materials, delivery to your booth, handling of empty containers to and from storage, and removal of your materials from your booth for reloading onto your outbound carrier. This is not to be confused with the cost to transport your exhibit material to and from the event.

Benefits of Advance Shipping to the Warehouse

- Storage of materials for up to 30 days prior to your show.
- Delivery of Shipments to your booth by the beginning of exhibitor move-in (schedule permitting).
- The hotel does not have facilities, space or procedures for receiving storing or moving exhibitor freight.
- Saves valuable set-up time.

How to ship goods

- Remove all old shipping and empty storage labels.
- Ensure goods are well labeled as yours for this event
- Complete the appropriate Material Handling order form.
- All shipments must have a bill of lading or delivery slip showing the number of pieces, weight, and type of merchandise.
- Take the time to ensure that your display and products are packed neatly and securely.
- Do not ship uncrated materials.
- If you are shipping your carpet and/or lighting trusses, make sure it is loaded last so it can be unloaded first.
- If shipping internationally, we recommend using a customs broker that specializes in clearing goods on a temporary basis - the broker assigned to your show is best.
- Your company/representative on site is responsible for all customs documents in AND OUT of Canada pre and post show (a hired broker would prepare these for you), proper labeling and filling out the waybill properly.
- If goods are sent incorrectly straight to site, and cannot be stored, they will be redirected to Calgary for storage and delivery at the proper time at the exhibitor's expense. If materials handling was not ordered, the goods may not be released to your booth until the service is ordered and paid for in full.
- Goods left to be shipped out that are not prepared (not taped, not labeled) by the exhibitor will incur full labour rates for this service.

Freight Carriers

Select a carrier with experience in handling exhibition materials. Make sure to give your carrier explicit information as to where and when to check-in. Delivery and pick up times are often out of the range of "normal" deliver hours, make sure your carrier is committed to meeting your target dates and times. While making shipping plans to the Show, also plan for the return shipment.

Tracking Shipments

Confirm your delivery date and time with your carrier, and have all pertinent shipping information in the hands of your representative at showsite. You may also want to review the return of your goods at the end of the show.

Estimating Material Handling Charges

Handling charges are based on the weight of the freight. Shipments are billed by the hundred weight and rounded up to the nearest hundred. Minimum per shipment may apply, see enclosed Material Handling Order Form for details. Please prepay all shipping charges - GES CANADA cannot accept or be responsible for collect shipments. Crated and uncrated shipments must be separated and clearly identified on your bill of lading.

- **Crated** - Material that is skidded, or is any type of shipping container that can be unloaded at the dock with no additional handling required.

- **Uncrated** - Material that is shipped loose or pad-wrapped, and/or unskidded machinery without proper lifting bars or hooks.

- **Special Handling** - Defined as shipments that are loaded by cubic space and/or packed in such a manner as to require special handling, such as ground loading, side door loading, constricted space loading, and designated piece loading or stacked shipments. Also included are mixed shipments and shipments without proper delivery receipts.

- **Overtime Surcharges** - Shows that move-in or move-out on weekends or late in the day may be subject to overtime surcharges. See enclosed Material Handling Order Form for details.

- **Late Surcharges** - A surcharge may apply if advance freight is received after the published deadline date for shipments to arrive at the warehouse. See enclosed Material Handling Order Form for details.

Storing Empty Containers

Properly labeled empty shipping cartons will be picked up, stored and returned after the show. Labels are available at the **GES CANADA Servicentre** or from your GES Service Executive and are for empty storage only. Depending on the size of the show, it can take from one (1) to four (4) hours to return empty crates. Do not store any items in crates marked empty.

Outgoing Shipments

A clearly completely filled out Bill of Lading must accompany all outgoing shipments. Shipping information, outbound forms and labels will be available at the **GES CANADA Servicentre**, if required, and must be completed by the exhibitor. Exhibitors selecting non-official carriers will need to make their own arrangements for pickup. Make sure that someone from your company will be on-site to oversee the outbound shipment of your display and product. If your designated carrier does not pick up or make destination delivery of your shipment on time, neither show management nor **GES CANADA** will be liable for any resulting delays, or expenses arising thereof.

Machinery Labour and Equipment

Labour and equipment for uncrating, unskidding, positioning, leveling, dismantling, recrating, and reskidding machinery and/or equipment must be ordered separately. If your material requires specialized rigging equipment, please notify us promptly so that we can make arrangements. When possible supply your own rigging equipment with shipments and pre-rig your material

Insurance

All of goods should be insured by your own insurance policy. Although we do our best to handle your goods as our own, there are many variables in shipping and handling that can affect your exhibit and products. GES CANADA has published GES CANADA Terms & Conditions of Contract that are in your exhibitor service manual. Please read them carefully. It is recommended that your goods be insured.

GES CANADA Limits of Liability

- **Liability** - GES is liable for loss or damage to your goods ONLY if the loss or damage was caused by GES CANADA negligence.

- **Measure of Damage** - If GES CANADA was negligent and the negligence caused either loss or damage to your goods, then the measure of that damage will be determined by the following:

a. Measure of damages in all situations (including b. below) will be limited by the Depreciated Value of the goods or repair costs, whichever is less.

b. The lesser of \$0.30 per pound per piece, \$50 per piece, or \$1000 per occurrence.

GES CANADA does not offer or sell insurance. GES CANADA is not liable and will not owe for loss or damage to your goods if the damage was not caused by GES CANADA.

GES BNF

EXHIBITION FREIGHT

FROM:

ADVANCE SHIPMENT

WAREHOUSE HOURS ARE MON - FRI 8:00 AM - 4:30 PM.

TO:

EXHIBITING COMPANY

Canadian Stewardship / RCA Conference

NAME OF EXHIBITION

BOOTH NUMBER

75 Dufferin PL S.E.
Calgary, Alberta T2C 4M3
Attention: GES Banff

SHIPMENT SHOULD ARRIVE ON OR BEFORE
September 25th, 2015



Number _____ of _____ pieces

PICK UP ADDRESS IS DIFFERENT, WILL BE FROM BANFF

GES BNF

EXHIBITION FREIGHT

FROM:

ADVANCE SHIPMENT

WAREHOUSE HOURS ARE MON - FRI 8:00 AM - 4:30 PM.

TO:

EXHIBITING COMPANY

Canadian Stewardship / RCA Conference

NAME OF EXHIBITION

BOOTH NUMBER

75 Dufferin PL S.E.
Calgary, Alberta T2C 4M3
Attention: GES Banff

SHIPMENT SHOULD ARRIVE ON OR BEFORE
September 25th, 2015



Number _____ of _____ pieces

PICK UP ADDRESS IS DIFFERENT, WILL BE FROM BANFF

GES BNF

EXHIBITION FREIGHT

FROM:

ADVANCE SHIPMENT

WAREHOUSE HOURS ARE MON - FRI 8:00 AM - 4:30 PM.

TO:

EXHIBITING COMPANY

Canadian Stewardship / RCA Conference

NAME OF EXHIBITION

BOOTH NUMBER

75 Dufferin PL S.E.
Calgary, Alberta T2C 4M3
Attention: GES Banff

SHIPMENT SHOULD ARRIVE ON OR BEFORE
September 25th, 2015



Number _____ of _____ pieces

PICK UP ADDRESS IS DIFFERENT, WILL BE FROM BANFF

GES BNF

EXHIBITION FREIGHT

FROM:

ADVANCE SHIPMENT

WAREHOUSE HOURS ARE MON - FRI 8:00 AM - 4:30 PM.

TO:

EXHIBITING COMPANY

Canadian Stewardship / RCA Conference

NAME OF EXHIBITION

BOOTH NUMBER

75 Dufferin PL S.E.
Calgary, Alberta T2C 4M3
Attention: GES Banff

SHIPMENT SHOULD ARRIVE ON OR BEFORE
September 25th, 2015



Number _____ of _____ pieces

PICK UP ADDRESS IS DIFFERENT, WILL BE FROM BANFF

USE THESE SHIPPING LABELS AS THEY WILL EXPEDITE HANDLING. Make copies as needed.

Furniture & Accessories Order Form

PO Box 960 Banff Alberta T1L 1J4 Phone: 403 762-2828 Fax: 403 762-2777 Email: banff@ges.com

Discount if ordered by
 September 16th, 2015

Please be advised that each exhibit booth will be supplied with one (1) regular height 4' or 6' skirted table. If you require a specific size table (6', or 4'), please complete this form and forward it to our office to reserve (no charge). The tables skirt will match the show colour(s) unless skirting colour change is ordered below.

Any on-site changes to the supplied tables will be charged at \$25.00 per change.

Supply my booth with 1 4' skirted table 6' skirted table

Additional tables can be ordered below

| Quantity | Item # | Description | Discount \$ | Regular \$ | Total Price |
|----------|--------|-------------|-------------|------------|-------------|
|----------|--------|-------------|-------------|------------|-------------|

Skirted Tables 2' deep x 29" high

| | | | | | |
|---|------|-----------------------------------|-----------|-----------|----|
| <i>Skirting for Tables - White Vinyl Top and Pleated Skirt on 3 Sides, Choose Colour below:</i> | | | | | |
| | DT4_ | Skirted 4' Table, Skirted 4 Sides | \$ 104.00 | \$ 131.00 | \$ |
| | DT6_ | Skirted 6' Table | \$ 104.00 | \$ 131.00 | \$ |
| | DT8_ | Skirted 8' Table | \$ 129.00 | \$ 159.00 | \$ |
| | DMS | Skirting colour change | \$ 33.00 | \$ 41.00 | \$ |
| | DMS | 4th Side Skirted, Optional | \$ 33.00 | \$ 41.00 | \$ |

Skirted Raised Tables 2' deep x 36" high

| | | | | | |
|--|------|-------------------------------------|-----------|-----------|----|
| <i>Skirting for Raised Tables - White Vinyl Top & Pleated Skirt on 3 Sides, Choose Colour below:</i> | | | | | |
| | RD4_ | Skirted 4' Counter, Skirted 4 Sides | \$ 131.00 | \$ 165.00 | \$ |
| | RD6_ | Skirted 6' Counter | \$ 131.00 | \$ 162.00 | \$ |
| | DMS | 4th Side Skirted, Optional | \$ 45.00 | \$ 57.00 | \$ |

Pedestal Tables 30" Diameter (finished top, unskirted)

| | | | | | |
|--|-------|-------------------------------------|-----------|-----------|----|
| | FCOFT | Round Coffee Table, 18" Tall | \$ 95.00 | \$ 120.00 | \$ |
| | FPEDT | Starbase Table, 30" Tall | \$ 96.00 | \$ 122.00 | \$ |
| | FPEDT | Cocktail Table, 42" Tall | \$ 109.00 | \$ 137.00 | \$ |
| | | Spandex Cover for 42" Table (Black) | \$ 32.00 | \$ 41.00 | \$ |

Chairs

| | | | | | |
|--|-------|----------------------------|----------|-----------|----|
| | FGFAC | Arm Chair, Padded Grey | \$ 47.00 | \$ 59.00 | \$ |
| | FGFCS | Counter Stool, Padded Grey | \$ 81.00 | \$ 100.00 | \$ |
| | FGFSC | Side Chair, Padded Grey | \$ 47.00 | \$ 59.00 | \$ |

Table/Raised Table Skirts/Drape Colours:

Show colour will be provided if no colour is indicated below:
Included table is in show colour(s) unless skirting colour change is ordered.
 Black, Blue, Burgundy, Charcoal, Forest Green, White.

TOTAL OF ALL ITEMS ORDERED: \$

Carry total to the payment and credit card authorization form

All orders governed by the GES CANADA payment policy & GES CANADA Terms & Conditions of Contract as specified in this Exhibitor's Kit. Cancellation Policy: Items cancelled will be charged 50% of original price after move-in begins and 100% after installation.

Specialty Items/Plants Order Form

PO Box 960 Banff Alberta T1L 1J4 Phone: 403 762-2828 Fax: 403 762-2777 Email: banff@ges.com

Discount if ordered by
 September 16th, 2015

PRICE LIST

| Quantity | Item # | Description | Discount \$ | Regular \$ | Total Price |
|----------|--------|---|-------------|--------------------------------|-------------|
| | FMISC | 10' POP UP BOOTH UNIT (velcro compatible) | \$ 580.00 | \$750.00 CALL FOR AVAILABILITY | \$ |

FS® FOLDING STACKABLE SYSTEMS (velcro compatible)

| | | | | | |
|--|-------|--|-----------|---------------------------------|----|
| | FMISC | FS TABLE TOP MODEL (6'10" across 35"h) | \$ 185.00 | \$ 240.00 CALL FOR AVAILABILITY | \$ |
| | FMISC | FS TABLE TOP WITH HEADER (47" h) | \$ 254.00 | \$ 320.00 CALL FOR AVAILABILITY | \$ |
| | FMISC | FS FULL HEIGHT MODEL (6'10" x 6'10") | \$ 381.00 | \$ 510.00 CALL FOR AVAILABILITY | \$ |

Display Items

| | | | | | |
|--|------|---|-----------|-----------|----|
| | FCSH | Signholder | \$ 61.00 | \$ 78.00 | \$ |
| | FESL | Easel | \$ 48.00 | \$ 61.00 | \$ |
| | FCT | Coat Tree | \$ 62.00 | \$ 79.00 | \$ |
| | FGR | Garment Rack on Wheels | \$ 62.00 | \$ 79.00 | \$ |
| | FCS | Stanchion & Rope | \$ 43.00 | \$ 54.00 | \$ |
| | FSBD | Ballot Drum, Table Size | \$ 77.00 | \$ 97.00 | \$ |
| | FSBD | Plexi lock box w/slot | \$ 107.00 | \$ 135.00 | \$ |
| | FLR | Literature stand (Accordion style floor standing 6 shelves) | \$ 124.00 | \$ 157.00 | \$ |
| | FBH | Bag Stand | \$ 78.00 | \$ 98.00 | \$ |
| | FWB | Wastebasket | \$ 22.00 | \$ 28.00 | \$ |

Green Floor Plants

| | | | | | |
|--|-------|----------------------------------|-----------|-----------|----|
| | PFP25 | 2' to 5' Tall (silk plant) | \$ 77.00 | \$ 97.00 | \$ |
| | PFP56 | 5' to 6' Tall (silk tree) | \$ 116.00 | \$ 146.00 | \$ |
| | PBF | Boston Ferns | \$ 109.00 | \$ 141.00 | \$ |
| | PMUM | Mums or Seasonal flowering plant | \$ 55.00 | \$ 70.00 | \$ |

ONSITE ORDERS MAY NOT BE AVAILABLE FOR THIS EQUIPMENT

| | | |
|--|---------------------------------------|--|
| Notes: | | |
| | TOTAL OF ALL ITEMS ORDERED: \$ | |
| Carry total to the payment and credit card authorization form | | |

All orders governed by the GES CANADA payment policy & GES CANADA Terms & Conditions of Contract as specified in this Exhibitor's Kit.

Cancellation Policy: Items cancelled will be charged 100% of original price after move-in begins.

COMPANY NAME

EMAIL ADDRESS

AUTHORIZED CONTACT

Electrical & Lighting Order Form

Discount if ordered by

PO Box 960 Banff Alberta T1L 1J4 Phone: 403 762-2828 Fax: 403 762-2777 Email: banff@ges.com

September 16th, 2015

PRICE LIST

| Quantity | Item # | Description | Discount \$ | Regular \$ | On Site Order \$ | Total Price |
|--|---------|---|-------------|------------|------------------|-------------|
| Electrical - 110 Volt | | | | | | |
| | EL1500W | 1500 Watt Duplex Outlet | \$ 118.00 | \$ 126.00 | \$ 165.00 | \$ |
| | EL2000W | 2000 Watt Duplex Outlet | \$ 133.00 | \$ 147.00 | \$ 173.00 | \$ |
| Electrical - Miscellaneous Requirements | | | | | | |
| | ELPB | Power Bars | \$ 24.00 | \$ 26.00 | \$ 30.00 | \$ |
| | ELEC | Extension Cords | \$ 24.00 | \$ 26.00 | \$ 30.00 | \$ |
| Lighting (Does Not Include Power) | | | | | | |
| | ELD150F | 8' Flood Light Stand, 2 - 75 Watt Flood Bulbs | \$ 79.00 | \$ 85.00 | \$ 106.00 | \$ |
| | ELMISC | 1 - 25w LED (as 200 watt) clamp on arm light | \$ 87.00 | \$ 97.00 | \$ 117.00 | \$ |
| | ELQL | 500 Watt Quartz Light | \$ 123.00 | \$ 180.00 | N/A | \$ |
| | ELMISC | Special Hookups & Specialty Lighting Available upon request | | | | \$ |

For Specialty or 3 phase Power please contact our office with details for further information and to receive a quote.

Please Note the Following:

- 24 Hour power - add 50% to the above prices
- Electrician Charge Extra, if required
- Additional labour charges may apply for special connections or special wiring

Notes:

TOTAL OF ALL ITEMS ORDERED: \$
 Carry this total to the payment and credit card authorization form

All orders governed by the GES CANADA payment policy & GES CANADA Terms & Conditions of Contract as specified in this Exhibitor's Kit.
 Cancellation Policy: Orders cancelled will be charged 50% of original price after move-in and 100% of original price after installation.

COMPANY NAME

EMAIL ADDRESS

AUTHORIZED CONTACT

Installation & Dismantle Labour Order Form

PO Box 960 Banff Alberta T1L 1J4 Phone: 403 762-2828 Fax: 403 762-2777 Email: banff@ges.com

Discount if ordered by
September 16th, 2015

PLEASE COMPLETE THIS FORM FOR ALL DISPLAY LABOUR NEEDED.

TO DETERMINE IF YOU NEED DISPLAY LABOUR, PLEASE READ THIS FORM CAREFULLY

- Display Labour is used for installation and dismantling of client owned exhibits, including signs and floor covering installation.

IMPORTANT INFORMATION & RATES

Starting time can be guaranteed only when labour is requested for the start of the working day at 8 AM. All exhibit labour for 8 AM starting times will be dispatched to booth space. For all other starting times, check in one-half (1/2) hour before time requested. Labour cancelled without a 24 hour notice shall be charged a one (1) hour cancellation fee per worker. If exhibitor fails to use the workers and equipment at the time confirmed, a one (1) hour "NO SHOW" charge per worker will apply.

GRATUITIES IN ANY FORM, INCLUDING CASH GIFTS, OR LABOUR HOURS FOR WORK NOT ACTUALLY PERFORMED ARE PROHIBITED BY GES. GES requires the highest standards of integrity from all employees. Please call our office at the above number to report fraudulent or unethical behavior.

All rates are subject to change if necessitated by increased labour and materials costs.

Straight Time
 8:00 am - 4:00 pm
 Monday - Friday
 \$ 82.00 Discounted
 \$ 110.00 Regular

Overtime
 After 4:00 pm Weekdays
 ALL Day Sat, Sun and holidays
 \$ 110.00 Discounted
 \$ 145.00 Regular

Labour rates are charged per person at a minimum charge of one (1) hour per worker. Labour thereafter is charged in half (1/2) hour increments.

A 30% surcharge will be applied to on-site orders.

EXHIBITOR MUST REPORT TO GES CANADA SERVICE CENTRE TO RECEIVE THEIR LABOUR

INSTALLATION Set up Drawings or Photos Attached yes no

SUPERVISION By Exhibitor (Name of Rep): _____ OR By GES - 30% surcharge applies
 (Exhibitor MUST be present and Supervise) (Exhibitor does not have to be present)

DATE LABOUR REQUIRED: _____ START TIME REQUIRED: _____ am pm
 Day/Date/Month/Year

NUMBER OF PEOPLE REQUIRED x TIMES HOUR PER PERSON = TOTAL HOURS X PRICE =

DISMANTLE

Carrier: _____ Pick up Date _____ Pick up Time: _____

SUPERVISION By Exhibitor (Name of Rep): _____ OR By GES - 30% surcharge applies
 (Exhibitor MUST be present and Supervise) (Exhibitor does not have to be present)

DATE LABOUR REQUIRED: _____ START TIME REQUIRED: _____ am pm
 Day/Date/Month/Year

NUMBER OF PEOPLE REQUIRED x TIMES HOUR PER PERSON = TOTAL HOURS X PRICE =

Terms & Conditions
 When Exhibitor is supervising labour the Exhibitor must check labour in and out at the GES Service Desk
 We reserve the right to change labourers and/or rates as shifts change
 Please estimate the number of workers and hours per worker needed for installation and dismantling above. Invoice will be calculated according to actual hours worked.

All claims or discrepancies must be settled within one week of show closing
 Uncancelled labour will be charged a minimum fee of 1 hour per person
 GES Limits of Liability apply

| | |
|----------------------|----|
| Total Labour Ordered | \$ |
|----------------------|----|

Notes: _____

Carry this total to the payment and credit card authorization form

Internal codes: LINDT LINOT LODT LOOT GES SUPERVISED GLINDT GLINOT GLODT GLOOT

All orders governed by the GES CANADA payment policy & GES CANADA Terms & Conditions of Contract as specified in this Exhibitor's Kit.

GEM Counters & Showcases Order Form

PO Box 960 Banff Alberta T1L 1J4 Phone: 403 762-2828 Fax: 403 762-2777 Email: banff@ges.com

Discount if ordered by
September 16th, 2015

GEM EXHIBIT ACCESSORIES & SHOWCASES

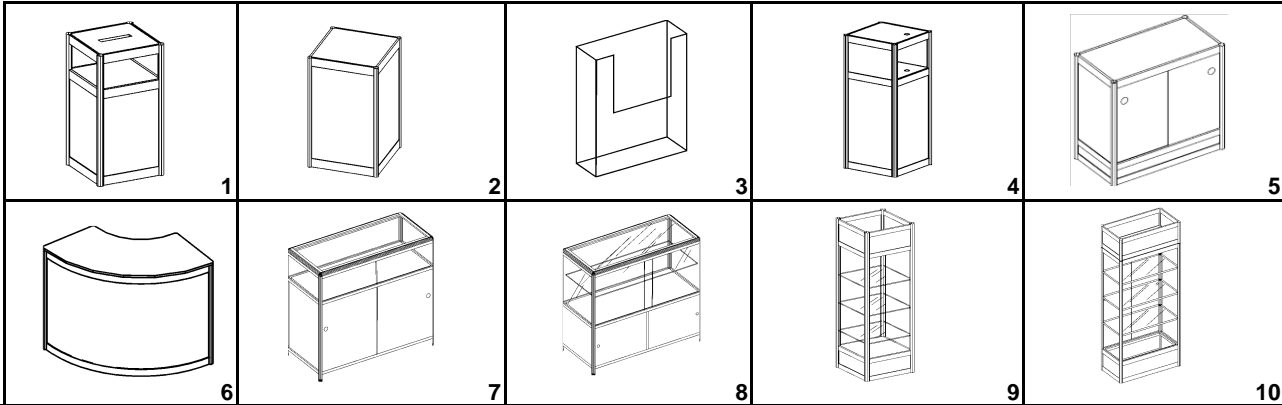

PRICE LIST

| Quantity | Item # | Description | Discount \$ | Regular \$ | Total Price |
|----------|---------|---|-------------|------------|-------------|
| | 1 GBB | Ballot Bin - 20"L X 20"W X 36"H | \$ 154.00 | \$ 216.00 | \$ |
| | 2 GPS | Pedestal White - 20"L X 20"W X 36"H | \$ 116.00 | \$ 162.00 | \$ |
| | 3 GPLP | 8.5" x 11" Clear Plexi Literature Pocket | \$ 37.00 | \$ 51.00 | \$ |
| | 4 GPS | A/V Pedestal (Black) 26"L X 26"W x 55"H | \$ 145.00 | \$ 203.00 | \$ |
| | 5 GCSU | Storage Counter (White with lock, \$30.00 key not returned) 40"L X 20"W X 40" H | \$ 256.00 | \$ 359.00 | \$ |
| | 6 GCC | Curve Counter (White) 60"L X 20"W X 36"H | \$ 271.00 | \$ 380.00 | \$ |
| | | Add your logo to the front of your counter - sign quality logo required, contact our office for details and a quote | | | \$ |
| | 7 G99A | 99A Showcase (White/Glass) 40"L X 20"W X 36"H | \$ 275.00 | \$ 385.00 | \$ |
| | 8 G99B | 99B Showcase (White/Glass) 40"L X 20"W X 36"H | \$ 294.00 | \$ 412.00 | \$ |
| | 9 G99C | 99C Showcase (White) 20"L X 20"W X 96"H | \$ 325.00 | \$ 455.00 | \$ |
| | 10 G99D | 99D Showcase (White) 40"L X 20"W X 96"H | \$ 452.00 | \$ 633.00 | \$ |
| | | Plexi panels to enclose 99C or 99D | call | call | \$ |

Notes:

Items 9 & 10 are not enclosed systems, glass shelves only

TOTAL OF ALL ITEMS ORDERED: \$

Carry this total to the payment and credit card authorization form

All orders governed by the GES CANADA payment policy & GES CANADA Terms & Conditions of Contract as specified in this Exhibitor's Kit. Cancellation Policy: Items cancelled will be charged 50% of original price after move-in begins and 100% after installation.

COMPANY NAME _____ EMAIL ADDRESS _____ AUTHORIZED CONTACT _____

Payment & Credit Card Charge Authorization Form MUST Accompany this Form

Transportation Order Form

PO Box 960 Banff Alberta T1L 1J4 Phone: 403 762-2828 Fax: 403 762-2777 Email: banff@ges.com

Arrange before
September 16th, 2015

| SHIPPER INFORMATION | | IF SHIPPING FROM ANOTHER SHOW PLEASE FILL IN THIS SECTION: | |
|------------------------------------|-------------------------|---|--|
| COMPANY/EXHIBITOR: | | SHIPPING FROM A SHOW: <input type="checkbox"/> YES <input type="checkbox"/> NO | BOOTH # |
| FACILITY/BUSINESS PICKING UP FROM: | ADDRESS: | SHOW NAME: | |
| CITY: | PR/ST POSTAL / ZIP CODE | MOVE-OUT DATE: | MOVE-OUT TIMES: |
| COUNTRY: | CONTACT: | SHOW CONTRACTOR: | MARSHALLING YARD: <input type="checkbox"/> YES <input type="checkbox"/> NO |
| PHONE: | FAX: | WILL BE SHIPPING TO THE ADVANCED WAREHOUSE <input type="checkbox"/> YES <input type="checkbox"/> NO | |

TAILGATE PICK UP REQUIRED? YES NO **LOADING DOCK?** YES NO

PICK UP HOURS:

| DESTINATION INFORMATION (Return after show) | | IF SHIPPING TO ANOTHER SHOW PLEASE FILL IN THIS SECTION: | |
|---|-------------------------|---|--|
| COMPANY/EXHIBITOR: | | SHIPPING TO A SHOW: <input type="checkbox"/> YES <input type="checkbox"/> NO | BOOTH # |
| FACILITY/BUSINESS DELIVERING TO: | ADDRESS: | SHOW NAME: | |
| CITY: | PR/ST POSTAL / ZIP CODE | MOVE-IN DATE: | MOVE-IN TIMES: |
| COUNTRY: | CONTACT: | SHOW CONTRACTOR: | MARSHALLING YARD: <input type="checkbox"/> YES <input type="checkbox"/> NO |
| PHONE: | FAX: | WILL BE SHIPPING TO THE ADVANCED WAREHOUSE <input type="checkbox"/> YES <input type="checkbox"/> NO | |

TAILGATE DELIVERY REQUIRED? YES NO **LOADING DOCK?** YES NO

DROP OFF HOURS:

| CUSTOMS INFORMATION | | | |
|---------------------|-------------------------|-----------------------|--|
| CUSTOMS BROKER: | CUSTOMS BROKER CONTACT: | CUSTOMS BROKER PHONE: | CUSTOMS PAPERWORK ATTACHED: <input type="checkbox"/> YES <input type="checkbox"/> NO |

PLEASE INDICATE SERVICE REQUIRED

ONE WAY ROUND TRIP REGULAR GROUND EXPEDITED GROUND

| ITEMS TO BE SHIPPED | | SERVICE WILL BE CHARGED ON ACTUAL WEIGHT & DIMENSIONS | |
|---------------------|------------------------------|---|------------------|
| TOTAL # OF PIECES | | DIMENSIONS IN INCHES | ESTIMATED WEIGHT |
| | CARTONS (CARDBOARD) | H _____ " x W _____ " x L _____ " | |
| | CASES/TRUNKS (FIBRE) COLOUR: | H _____ " x W _____ " x L _____ " | |
| | CRATES (WOODEN) | H _____ " x W _____ " x L _____ " | |
| | SKIDS/PALLETS | H _____ " x W _____ " x L _____ " | |
| | CARPET - COLOUR: | H _____ " x W _____ " x L _____ " | |
| | OTHER - LIST: | H _____ " x W _____ " x L _____ " | |
| | TOTAL# OF PIECES | TOTAL WEIGHT | |

| CREDIT CARD CHARGE AUTHORIZATION | | <input type="checkbox"/> MasterCard <input type="checkbox"/> VISA <input type="checkbox"/> American Express | | | | | | | | | | | | | | | | |
|----------------------------------|--------------|--|-----------|--|--|--|--|--|--|--|--|--|--|--|--|--|--|--|
| CARDHOLDER'S NAME | PLEASE PRINT | <table border="1"> <tr> <td>Account #</td> <td></td> <td></td> <td></td> </tr> <tr> <td></td> <td></td> <td></td> <td></td> </tr> <tr> <td></td> <td></td> <td></td> <td></td> </tr> <tr> <td></td> <td></td> <td></td> <td></td> </tr> </table> | Account # | | | | | | | | | | | | | | | |
| Account # | | | | | | | | | | | | | | | | | | |
| | | | | | | | | | | | | | | | | | | |
| | | | | | | | | | | | | | | | | | | |
| | | | | | | | | | | | | | | | | | | |
| CARDHOLDER'S BILLING ADDRESS | CITY | | | | | | | | | | | | | | | | | |
| PROVINCE / STATE | POSTAL CODE | | | | | | | | | | | | | | | | | |
| CARDHOLDER'S SIGNATURE | | DATE | | | | | | | | | | | | | | | | |
| | | EXPIRATION DATE | | | | | | | | | | | | | | | | |

TERMS AND CONDITIONS
 GES CANADA assumes no responsibility for shipments left in booth by exhibitor. All materials are subject to final count and correction at time of actual removal from booth. Shipper hereby designates GES as its agent for tendering shipments to carrier. GES CANADA reserves the right to reroute any outgoing shipment via an alternate carrier in the event the requested carrier fails to pick up the shipment by established carrier check-in deadline. GES CANADA assumes no responsibility for misdirected shipments as a result of old shipping labels which remain on containers. It is the shipper's responsibility to state the national motor freight classification commodity description, otherwise shipment shall be described as exhibition materials.

1) GES CANADA shall not be responsible for damage to uncrated materials, materials improperly packed or concealed damage. 2) GES CANADA shall not be responsible for loss, theft, or disappearance of exhibitors material after the same has been delivered to exhibitor's booth. 3) GES CANADA shall not be responsible for loss theft or disappearance of materials before they are picked up from exhibitor's booth for reloading after the show. Bill of Lading covering outgoing shipments, which are furnished by GES to exhibitors, will be checked at time of actual pick-up from booth and corrections made where discrepancies occur. 4) GES CANADA shall not be responsible for any loss, damage or delay due to fire, acts of God, strikes, lockouts or work stoppages of any kind, or to any causes beyond its control. 5) GES CANADA shall be limited to the physical loss or damage to the specific article which is lost or damaged, and in any event GES CANADA's maximum liability shall be limited to \$0.30 per pound per article with a maximum liability of \$50 per item, or \$1000.00 per shipment, whichever is less. 6) GES CANADA shall not be liable to any extent whatsoever for any actual, potential, or assumed losses of profits or revenues, or for any collateral costs, which may result from any loss or damage to exhibitor's materials which may make it impossible or impractical to exhibit same. 7) The consignment or delivery of a shipment to GES CANADA by an exhibitor, or by any shipper to or on behalf of the exhibitor shall be construed as an acceptance by such exhibitor (and/or shipper) of the terms and conditions set forth. Exhibitor is responsible to declare all hazardous materials and abide by federal, state and local laws.

All orders governed by the GES CANADA payment policy & GES CANADA Terms & Conditions of Contract as specified in this Exhibitor's Kit.

AUTHORIZED SIGNATURE _____ AUTHORIZED CONTACT _____ COMPANY NAME _____ EMAIL ADDRESS _____

X

MATERIALS HANDLING SERVICE IS STILL REQUIRED IF TRANSPORTATION IS ORDERED BY SIGNING THIS FORM, SHIPPER AGREES TO BE BOUND BY ALL ITS TERMS & CONDITIONS

1. GES CANADA Exposition Services herein known as GES and its subcontractors shall not be responsible for damage to uncrated materials; materials improperly packed, glass breakage or concealed damage.

2. Relative to inbound shipments, there may be a lapse of time between the delivery of shipment(s) to the booth by GES or its subcontractors and the arrival of the Exhibitor's representative at the booth. Similarly, relative to outgoing shipment(s), it is possible that there will be a lapse of time between the completion of packing and the actual pick-up of materials from the booth for loading onto a carrier. It is understood that during such times the shipment(s) will be left in the booth unattended.

Therefore, it is agreed that GES and its subcontractors are not responsible for the loss or disappearance of Exhibitor's materials after the same have been delivered to Exhibitor's booth, nor are GES and its subcontractors responsible for Exhibitor's materials before they are picked up from the Exhibitor's booth for loading after the show. Consequently, all bills of lading covering outgoing shipment(s) submitted to GES or its subcontractors by Exhibitor will be checked at the time of pick-up from the booth and corrected where discrepancies exist.

3. GES and its subcontractors shall not be held liable for any damage incurred during the handling of equipment requiring special devices to properly load, place or reload unless advance notice has been given to GES in time to obtain the proper equipment.

4. GES and its subcontractors shall not be responsible for loss, delay or damage due to strikes, lockouts or work stoppages of any kind.

5. GES and its subcontractors shall not be responsible for ordinary wear and tear in handling of equipment, nor for loss or damage due to fire, theft, windstorm, water, vandalism, acts of God, mysterious disappearance or other causes beyond their control.

6. It is understood that GES and its subcontractors are not insurers. Insurance, if any, shall be obtained by the Exhibitor. Amounts payable to GES hereunder are based on the scope of the liability as herein set forth and are unrelated to the value of the Exhibitor's property. It is further understood and agreed that GES and its subcontractors do not provide for full liability should loss or damage occur. It is agreed that if GES or its subcontractors should be found liable for loss or damage to Exhibitor's equipment, the liability shall be limited to the specific article that was physically lost or damaged. Such liability shall be limited to a sum equal to \$0.30 per pound per article, with a maximum liability of \$50.00 per item or \$1,000.00 per shipment, whichever is less, as agreed upon damages and exclusive remedy. Provisions of this paragraph shall apply if loss or damage, regardless of cause or origin, results directly or indirectly to property through performance services to

Exhibitor's or from negligence, active or otherwise, by GES, its subcontractors or their employees.

7. GES and its subcontractors shall not be liable to any extent whatsoever for any actual, potential or assumed loss of profits or revenues or for any collateral costs that may result from any loss or damage to Exhibitor's materials which may make it impossible or impracticable to exhibit same.

8. Claims for loss or damage must be submitted to GES by the close of the show. No suit or action shall be brought against GES or its subcontractors more than one year after the cause of action.

9. The Exhibitor agrees, in connection with the receipt, handling, temporary storage and reloading of its materials, that GES and its subcontractors will provide these services as Exhibitor's agent and not as bailee or shipper. If any employee of GES or its subcontractors shall sign a delivery receipt, bill of lading or other document, we agree that GES or its subcontractor will do so as the Exhibitor's agent, and the Exhibitor accepts the responsibility thereof.

10. GES and its subcontractors shall not be liable for shipments received without receipts, freight bills or specified unit counts on receipts or freight bills, such as a courier or van lines. Such shipments will be delivered to booth without guarantee of piece count or condition.

11. Empty container labels will be available at the GES Service Centre. Affixing the labels is the sole responsibility of the Exhibitor or its representative. It is understood that these labels are used for EMPTY STORAGE ONLY, and GES and its subcontractors assume no responsibility for loss or damage to contents while containers are in storage or for mislabelled containers.

12. In order to expedite removal of materials from the show site, GES shall have the authority to change designated carriers, if such carriers do not pick up on time. Where no disposition is made by the Exhibitor, materials will be taken to a warehouse to await Exhibitor's shipping instructions, and the Exhibitor agrees to be responsible for payment of charges relating to such handling at the warehouse. GES assumes no liability as a result of such re-routing or handling.

13. The Exhibitor agrees, in the event of a dispute with GES or its subcontractors relative to any loss or damage to any of your materials or equipment, that the Exhibitor will not withhold payment in any amount due to GES for material handling services or any other services provided by GES or its subcontractors as an offset against the amount of the alleged loss or damage. Instead, the Exhibitor agrees to pay GES prior to the close of the show for all such charges and further agrees that any claim the Exhibitor may have against GES or its subcontractors shall be pursued independently by the Exhibitor as a completely separate transaction to be resolved on its own merits.

The consignment or delivery of a shipment to GES or its subcontractors by an Exhibitor or by any shipper on behalf of the Exhibitor shall be construed as an acceptance by such Exhibitor (and/or other shipper) of the terms and conditions set forth in Sections 1 through 13 above.

Be sure your materials are insured from the time they leave your firm until they are returned after the show. It is suggested that Exhibitors arrange all risk coverage. This can usually be done by riders to existing policies. Contact your insurance representative. Be sure your liability insurance is in effect during transit and return of your materials, during storage and at show site.